

Chesterton Mechanical Seals and Valve Packing

Challenge

Maintaining reliable seals and packing for valves of critical pumps is essential for safe, reliable operation of nuclear power plants. Seal failures and packing defects in rotating equipment can cause a plant shutdown, resulting in costly lost revenue.

Solution

Framatome is now the prime channel to the market for Chesterton mechanical seals and valve packing. With more than a century of providing valve sealing products, Chesterton has an outstanding reputation for high-quality, innovative products with proven performance.

Framatome's Nuclear Parts Center offers responsiveness 24-hours a day, 365 days a year with ready-to-ship inventory, strong technical support and an online inquiry system. The NPC is the one-stop shop for valve and rotating equipment solutions, and has been delivering parts to the nuclear industry for forty years.

Seals

Chesterton is a world leader in design innovation of split seals. Their innovative split seals have been used to seal thousands of process-critical pieces of rotating equipment with exceptional results and in many cases years of leak-free operations.

Chesterton was the first company to offer commercially-viable split seals for plant-wide use, which revolutionized pump sealing across industries. Since that time, they have launched a number of innovative split seal designs now used as a standard by companies around the globe. Shaft diameters are available ranging from 25-914 mm (1-36 in.).

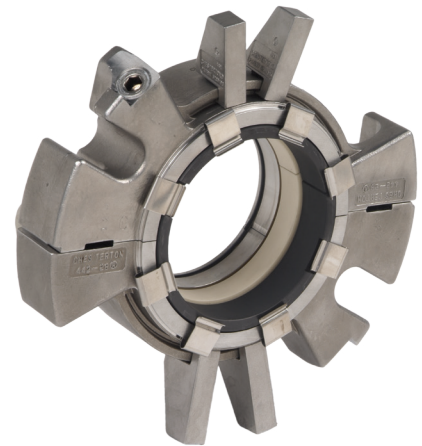

Chesterton 442 Split Seal

High-performance seals available in large diameters

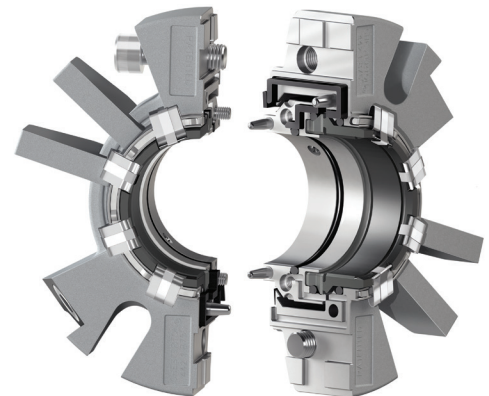

Chesterton 442C Cartridge Split Seal

Enhanced design for simple installation and greater sealing reliability

Your performance
is **our** everyday **commitment**

Customer benefits

- Improve rotating equipment reliability and efficiency, and extend life
- Reduce operating and maintenance costs
- NPC offers responsiveness – 24 hours a day, 365 days a year
- Qualification and dedication services
- Ready to ship inventory with strong technical support
- Meet quality requirements with Framatome's Appendix B Program

Packing

Motor Operated Valves Solutions

Chesterton® 5300 sealing system meets the sealing requirements of Motor Operated Valves. These valves are often difficult to seal due to their demanding services and physical size. MOVs are often critical to plant operation and safety and leave no margin for error. The 5300 can withstand temperatures up to 2760° C (5000° F) in a non-oxidizing atmosphere.

Air Operated Solutions

For Air Operated Valves, Chesterton 5800 WedgeSeal™ packing system reduces stem friction and gland loads. The WedgeSeal arrangement transfers gland force with predictable precision. WedgeSeal sealing rings are available in low friction, PTFE mesh over graphite construction or pure graphite. Both meet API 589 Fire Test requirements.

Block Valve Solutions

Chesterton 1601 packing combines layers of graphite strands braided into one. Each strand is reinforced by an Inconel® mesh covering and is braided to form a dense pliable packing. The 1601 is then impregnated with high-temperature blocking agents, lubricants and a passive corrosion inhibitor.

Committed to ensuring your performance, Framatome stands ready to assist you with your mechanical seal and valve packing needs.



Scan to view our parts on the web:
www.framatome.com/npc

OFF HOURS Cell Phone Coverage:
434.610.3880

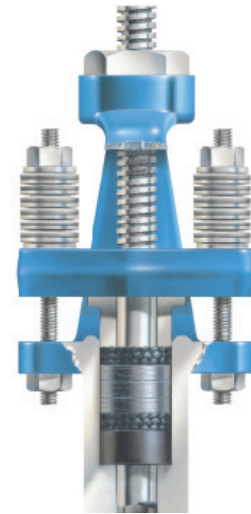

Chesterton 5300 Solution

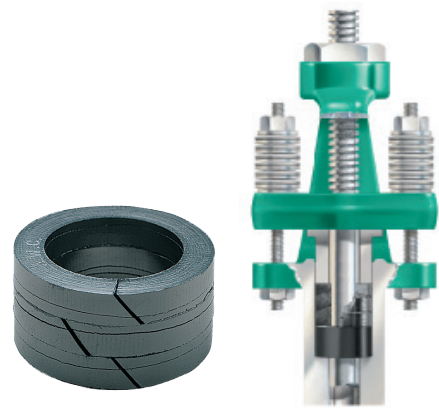

Chesterton 5800 WedgeSeal™ Solution



Chesterton 1601 Solution

Contact:

Ron Jaworowski, PMP • Tel: 704.805.2180 • Ronald.Jaworowski@framatome.com
Installed Base North America Sales • Tel: 704.805.2022 • IBNASales@framatome.com

www.framatome.com/us

Chesterton is a registered trademark of A.W. Chesterton Company. WedgeSeal is a trademark of A.W. Chesterton Company. Inconel is a registered trademark of the Special Metals Corporation group of companies. The data and information contained herein are provided solely for illustration and informational purposes and create no legal obligations by Framatome Inc. None of the information or data is intended by Framatome Inc. to be a representation or a warranty of any kind, expressed or implied, and Framatome Inc. assumes no liability for the use of or reliance on any information or data disclosed in this document. ©2018 Framatome Inc. All rights reserved. PS_US_695_ENG_05-18



framato**me**