

Jet Pump Beam Inspection

Simple, Reliable Pole-Delivered UT Inspection

Inspection transducers conform to the jet pump beam surface, minimizing schedule impact for component inspection.

Challenge

Detecting Cracking Throughout Entire Transition Region of Beam

Utilities want innovative ultrasonic solutions that detect cracks in the entire transition area of their jet pump beams.

Solution

A Proven, Time-Saving Solution for Challenging Inspections

Framatome provides the Jet Pump Beam Inspection Tool (JPBIT) to help ensure top plant performance. The JPBIT is a stationary fixture and is easily delivered with standard poles from either a refueling bridge, auxiliary bridge, or work platform or deployed in parallel with our HawkEye In Vessel Visual Inspection (IVVI) system. In preparation for inspection, the tool is easily centered on the jet pump beam bolt and aligned from the sides of the hold-down beam. The examination fixture is designed to position each of the five transducers at a predetermined locations to provide examination coverage of the regions of interest.

During inspection, three transducers are moved along two linear slides above the beam's surface. Two of the transducers inspect down the taper of the beam, while the third inspects up the taper of the beam. The remaining two stationary transducers simultaneously inspect the target areas of both the beam-bolt thread area and the ear-end area.

Qualification testing has shown the tool capable of inspecting the beam-bolt thread area, up and down the 25-degree taper, the beam's radii edges, and horizontal surfaces of the beam. This progressive approach delivers complete inspection of the beam's surface area.

A Standard in Efficiency and Reliability

To decrease inspection time and increase inspection coverage area, Framatome's JPBIT provides a complete evaluation of your beams' material condition. Make informed and proactive decisions regarding costly replacements — and eliminate worrying about jet pump beam failure. Because of its practical design and ease of installation, JPBIT can inspect all 20 beams in only 12 to 14 hours.

Customer benefits

- Satisfies all inspection requirements
- Increases inspection coverage to include entire transition area of beam
- Reduces critical path time
- Practical design ensures reliable, cost-effective operation
- Provides valuable input and flexibility for long-term replacement options
- Can be deployed to perform inspections in parallel with HawkEye IVVI inspections

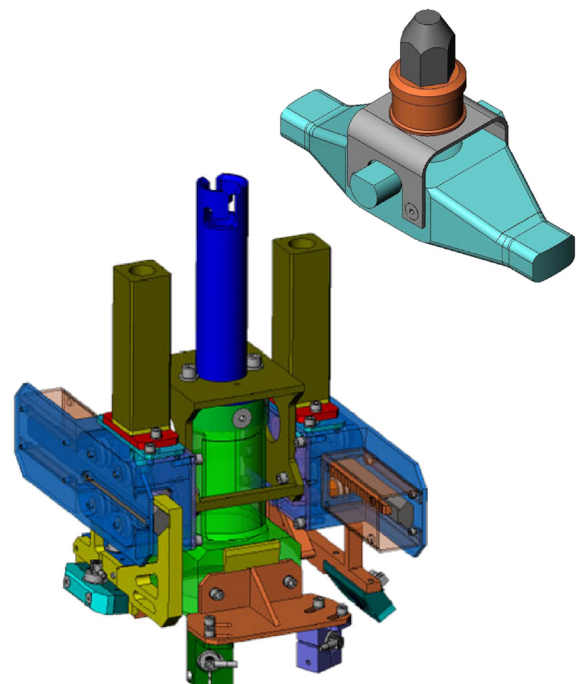

Your performance
is **our** everyday **commitment**

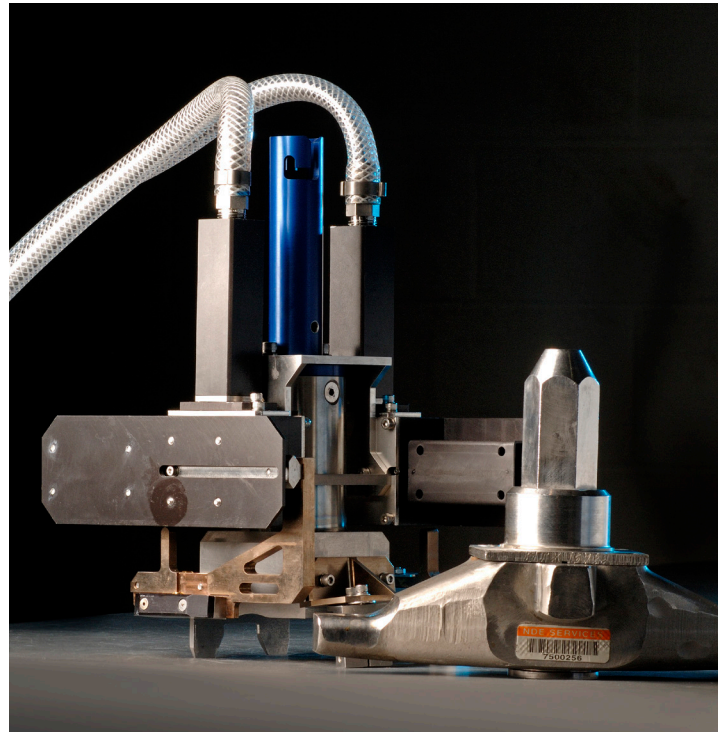

Practical design enables efficient operation — inspect up to 20 beams per 12-hour shift.

Contact: examination@framatome.com
www.framatome.com/us

The data and information contained herein are provided solely for illustration and informational purposes and create no legal obligations by Framatome Inc. None of the information or data is intended by Framatome Inc. to be a representation or a warranty of any kind, expressed or implied, and Framatome Inc. assumes no liability for the use of or reliance on any information or data disclosed in this document. ©2018 Framatome Inc. All rights reserved. PS_US_041_ENG_11-18

framatome