

DEFECTIVE FUEL ROD TREATMENT

for Interim and Long-Term Dry Storage

A reliable, economic and flexible encapsulation technology for safe enclosure of defective fuel rods

Challenge

Defective spent fuel management is becoming a major challenge for nuclear power plant (NPP) operators. When a NPP approaches the end of its operating lifetime, the owner wants to relocate the fuel to long-term solutions. Removal and storage of fuel is routine for fuel assemblies with sound fuel rods. For those with defective fuel rods, however, special handling and remediation are required.

Solution

We provide a technology to safely enclose defective fuel rods for dry storage. Single rod encapsulation and associated capsule canister designs allow flexibility for further handling. The methodology is based on our comprehensive and long-standing experience in field services for irradiated fuel assemblies and fuel rods.

The single rod encapsulation is performed on site in the spent fuel pool. The following major operations are executed:

Preparation work

- Defective rods have been extracted out of fuel assemblies before encapsulation
- Insertion of the defective fuel rod in the fuel rod capsule

Single rod encapsulation

- Drying the defective fuel rod inside the capsule by inert hot gas
- Gas-tight closure of the fuel rod capsule by welding
- Non-destructive testing of the capsule weld seams by visual test and ultrasonic test
- Transfer of the fuel rod capsule into the capsule canister

Subsequent work

- Transfer of the loaded capsule canister to the transport and storage cask
- Shipment of the loaded transport and storage cask to the dry interim storage facility

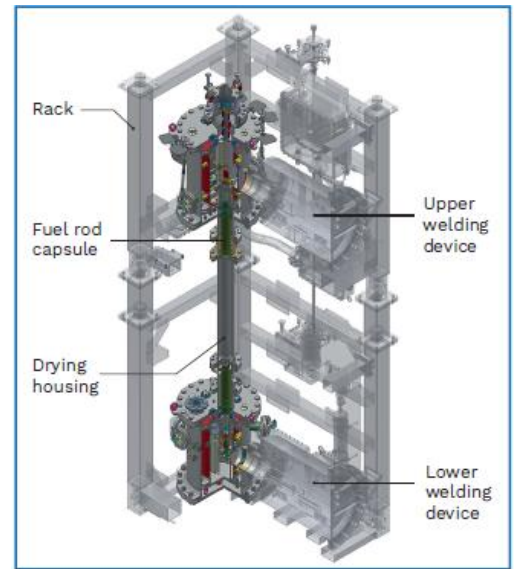

Encapsulation facility for use in the spent fuel pool (sectional view)
© Framatome

Customer benefits

- Encapsulation provides a solution for defective fuel (fuel-free plant) as precondition before starting dismantling and decommissioning activities
- Significant economic advantages as capsule canisters can be loaded along with fuel assemblies within one transport or storage cask
- Health and ALARA requirements are met without extra shielding
- Technology is independent of type of cask
- Flexibility in further handling due to encapsulation of single rods
- Advantages for transport and storage cask licensing based on easy comprehensible technology

Your performance
is our everyday **commitment**

Technical information

Fuel rod capsules

- Design is applicable to all kinds of defective fuel rods in terms of damage classification
- Radioactive material dispersion is limited to the inventory of a single fuel rod
- Material properties of the capsule are in alignment with the safety requirements for transport and interim storage
- Remaining moisture of one capsule is physically verifiable
- The permitted residual water content of a capsule meets the cask requirements

Capsule canisters

- Design, loads and handling conditions are similar to pressurized water reactor (PWR) / boiling water reactor (BWR) fuel assemblies
- Flexible arrangement of fuel rod capsules within the capsule canister up to the maximum loading capacity
- Compatible with transport and storage cask for dry interim storage

References

First application was successfully performed in a European nuclear plant at the beginning of 2018.

Scan the QR Code to watch the webinar on Framatome's most recent developments in Fuel Services Technology, by the European Nuclear Society:

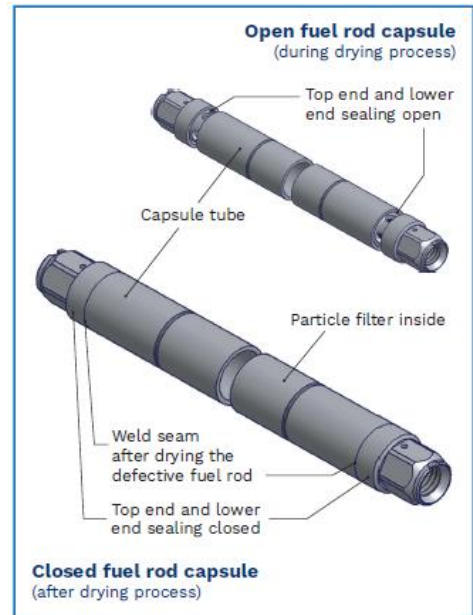

Fuel rod capsule safely enclosing the defective fuel rod

© Framatome

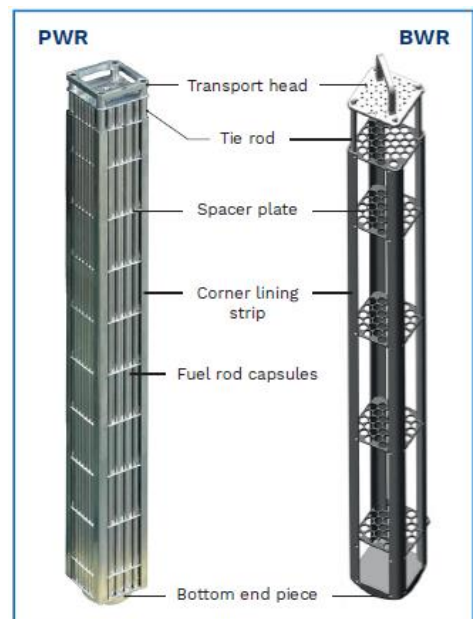

Handling conditions are similar to fuel assemblies

© Framatome

Contact : sales-fuel@framatome.com
www.framatome.com

It is prohibited to reproduce the present publication in its entirety or partially in whatever form without prior written consent. Legal action may be taken against any infringer and/or any person breaching the aforementioned prohibitions.

Subject to change without notice, errors excepted. Illustrations may differ from the original. The statements and information contained in this publication are for advertising purposes only and do not constitute an offer of contract. They shall neither be construed as a guarantee of quality or durability, nor as warranties of merchantability or fitness for a particular purpose. These statements, even if they are future-orientated, are based on information that was available to us at the date of publication. Only the terms of individual contracts shall be authoritative for type, scope and characteristics of our products and services.

framatome